

City of Rohnert Park

Southeast Specific Plan

Adopted December 2010

Amended November 25, 2014
Resolution No. 2014-164

Amended April 23, 2019
Resolution No. 2019-044

Amended August 8, 2023
Resolution No. 2023-064

TABLE OF CONTENTS

PAGE

1. INTRODUCTION	
A. Background and Plan Purpose	1
B. Planning Process	1
C. Specific Plan Contents	2
D. How to Use This Plan	2
E. Statutory Authority	3
F. Relationship to the General Plan	3
G. Relationship to Other Plans and Regulations	4
2. DESCRIPTION OF PLAN AREA	
A. Regional Setting	5
B. Local Setting	5
C. General Site Characteristics	5
D. Jurisdictions	7
3. LAND USE ELEMENT	
A. Introduction	8
B. Land Use Policies	8
C. Land Use Designations	8
D. Land Use Designations Summary	13
E. Affordable Housing	15
4. DEVELOPMENT STANDARDS	16
5. CIRCULATION ELEMENT	
A. Existing Circulation	19
B. Roadway Classifications and Standards	19
C. Transit Service	20
D. Pedestrian and Bicycle Circulation	20
E. Private Drive / Lane	21
F. Projected Traffic Volumes	21
G. Emergency Vehicle Access	21
H. Phasing	21
6. PUBLIC SERVICES ELEMENT	
A. Introduction	24
B. Access and Circulation	24
C. Water Service	24
D. Sanitary Sewer Service	25
E. Storm Drainage System	25
F. Parks and Recreation	26
G. Schools	26
H. Police and Fire	26
I. Finances	26

7. DESIGN GUIDELINES	28
8. IMPLEMENTATION ELEMENT	
A. Development Review and Approval Process	29
B. Financing	29
C. Amendments to the Specific Plan	29
LIST OF ATTACHMENTS	30
LIST OF RELATED TECHNICAL STUDIES	30

<u>LIST OF FIGURES</u>	<u>PAGE</u>
Figure 2-1 Specific Plan Areas	6
Figure 3-1 Conceptual Land Use Plan	10
Figure 3-2 Conceptual Development Plan	11
Figure 3-3 Mixed Use Area	14
Figure 5-1 Circulation Plan	22
Figure 5-2 Conceptual Phasing Plan	23

<u>LIST OF TABLES</u>	<u>PAGE</u>
Table 2-1 SESPAs Parcels	5
Table 3-1 Permitted Uses	13
Table 3-2 SESPAs Land Use Program	14
Table 4-1 Development Standards	17

1. INTRODUCTION

A. Background and Plan Purpose

The present document has been prepared in response to the City of Rohnert Park's Municipal Code Chapter 17.06, Article VIII, Sections 17.06.290-450, SP-Specific Plan District. This chapter outlines the requirements for the preparation, adoption and implementation of Specific Plans in certain areas of the community. The Southeast Specific Plan area, the subject of this Plan document, was identified in the City's General Plan, as adopted in July of 2000 and amended in 2010. The purpose of the Plan, consistent with the aims of Chapter 17.06, SP-Specific Plan District, is to provide a vehicle for ensuring that this area of the City is master planned. It is also to ensure that the phasing and ultimate development of the property involved is consistent with a vision that is both compatible with the existing community and responsive to the vision of the General Plan.

B. Planning Process

As outlined in the aforementioned Chapter of the Municipal Code, there are two primary phases of activity that the Specific Plan process entails. The first of these is the submission of a Preliminary Application that is then followed with a Specific Plan, the subject of the present document. A Preliminary Application for the Southeast Specific Plan was submitted to the City of Rohnert Park in February of 2002. In preparing the Preliminary Application, the property owners, Penn Grove Mountain, LLC, undertook the preparation of a variety of engineering and technical studies to both document the existing conditions on the site as well as to develop some preliminary concepts for the physical development of the land uses and activities established for this area in the General Plan; in addition, several meetings were held with representatives of the City of Rohnert Park to discuss the proposed Specific Plan. Upon completion of the Preliminary Application and presentation to the Planning Commission and the City Council, additional technical studies were undertaken as well as a process of interaction with representatives of the City of Rohnert Park to review more detailed information on the proposed development. Following the Specific Plan procedure, the present document was submitted to the City of Rohnert Park and a draft Environmental Impact Report was prepared. The present document reflects, therefore, the information contained in the Preliminary Application as well as the subsequent refinement of plan concepts and incorporates feedback from the City's representatives. The present document will be submitted to the Planning Commission and City Council for review and public hearings. Upon the approval of the City Council the Plan will be implemented as an ordinance.

C. Specific Plan Contents

The present Plan contains the following four elements:

- Land Use, which establishes the land use pattern and standards for uses allowed in the plan area;
- Circulation, which, based on the transportation requirements generated by the land uses in the Plan area, establishes a circulation system necessary to accommodate vehicular and pedestrian movements.
- Public Services, which based on the land use pattern outlines the strategies for providing public safety, recreation, utility and school services.
- Design Guidelines, which address recommended site planning, building and open space relationship, architecture and land design and public access; and
- Implementation, which provides information on the actions needed to implement the Plan, including General Plan and zoning changes, if needed, and phasing.

D. How to Use This Plan

As adopted by the City of Rohnert Park, the Plan represents a public document that establishes the amount, type and location of urban development that will be permitted in the Southeast Specific Plan area. The Plan also provides development standards and design guidelines for the development and recommends specific actions to implement the plan and financing methods and sources to fund improvements.

As the property owners move forward to implement the project, the detailed development plans will be subject to review by the City for consistency with the Specific Plan. It is anticipated that the future development plans for the area will be consistent with the Specific Plan and therefore the environmental issues associated with development will have been assessed in the environmental documentation which has been prepared as part of the Specific Plan process. Further assessment, if required, can be limited to site-specific impacts of the individual development plans.

Subsequent steps in the development process, including Development Area Plans, subdivision and other procedures are administered according to the Municipal Code.

E. Statutory Authority

California Law, specifically Section 65450-65457 of the Government Code, empowers cities to employ specific plans to provide for the systematic implementation of the General Plan by linking the implementing policies of the General Plan with the individual development proposals in a defined area.

This Specific Plan conforms to the various principles and requirements of State Planning and Zoning Law, Article 8, Specific Plans of Chapter 3. Local Planning by providing the following information:

- (1) The distribution, location, and extent of the uses of land, including open space, within the area covered by the plan.
- (2) The proposed distribution, location, and extent and intensity of major components of public and private transportation, sewage, water, drainage, solid waste disposal, energy, and other essential facilities proposed to be located within the area covered by the plan and needed to support the land uses described in the plan.
- (3) Standards and criteria by which development will proceed, and standards for the conservation, development, and utilization of natural resources, where applicable.
- (4) A program of implementation measures including regulations, programs, public works projects, and financing measures necessary to carry out paragraphs (1), (2), and (3).
- (5) A statement of the relationship of the specific plan to the general plan.

F. Relationship to the General Plan

The City of Rohnert Park's General Plan provides a comprehensive statement of the objectives, themes and policies which the community is seeking to achieve in the areas of land use, growth management, community design, transportation, open space, parks and public facilities, environmental conservation, health and safety, noise, and housing. The current Specific Plan, as an instrument which promulgates and is an extension of the General Plan, incorporates, by definition, the stated general objectives, themes and policies and, where more specific objectives and policies are stated, makes reference to such objectives and policies and provides further elaboration on the ways in which the Specific Plan is responsive to this guidance.

A comprehensive discussion of the General Plan goals, policies, and programs that provide direction and input to the Southeast Specific Plan and the various related elements are included as Attachment C: General Plan Analysis.

G. Relationship to Other Plans and Regulations

The Southeast Specific Plan Area (SESPA) is within Sonoma County and within the City of Rohnert Park's Sphere of Influence and 20-year Urban Growth Boundary. Annexation into the City of Rohnert Park has been completed and the specific plan area is currently under development. Actions required for the ongoing implementation of the Specific Plan are discussed in greater detail in Chapter 7: Implementation.

Policy documents and ordinances of both of Sonoma County and The City of Rohnert Park provide guidance on the development process and requirements in the plan area. State and regional agencies also exercise jurisdictional authority over development activities in the plan area. The following City policy documents apply to the plan area:

- City of Rohnert Park General Plan
- City of Rohnert Park Zoning Ordinance

2. DESCRIPTION OF PLAN AREA

A. Regional Setting

The City of Rohnert Park is located in central Sonoma County approximately a one hour drive north of the San Francisco Bay Area. With the Pacific Ocean to the west, the community lies within the Cotati Valley and is bounded to the south by the City of Cotati while the City of Santa Rosa lies to the north.

B. Local Setting

As shown in Figure 2-1, the Southeast Specific Plan Area (SESPA) lies within the City of Rohnert Park's city limit in the extreme southeast corner of the City. The SESPA is bounded to the north by the Canon Manor Specific Plan Area, to the east by Petaluma Hill Road and undeveloped land, to the south Valley House Drive and undeveloped land, and to the west by Bodway Parkway and land in the Sonoma Mountain Village Planned Development.

C. General Site Characteristics

The SESPA consists of relatively flat land rising gently from east to west with no significant natural or manmade features or changes in topography. The neighborhood park is complete and phase 3 is currently under development. The current development and remaining development are as shown in Table 2-1.

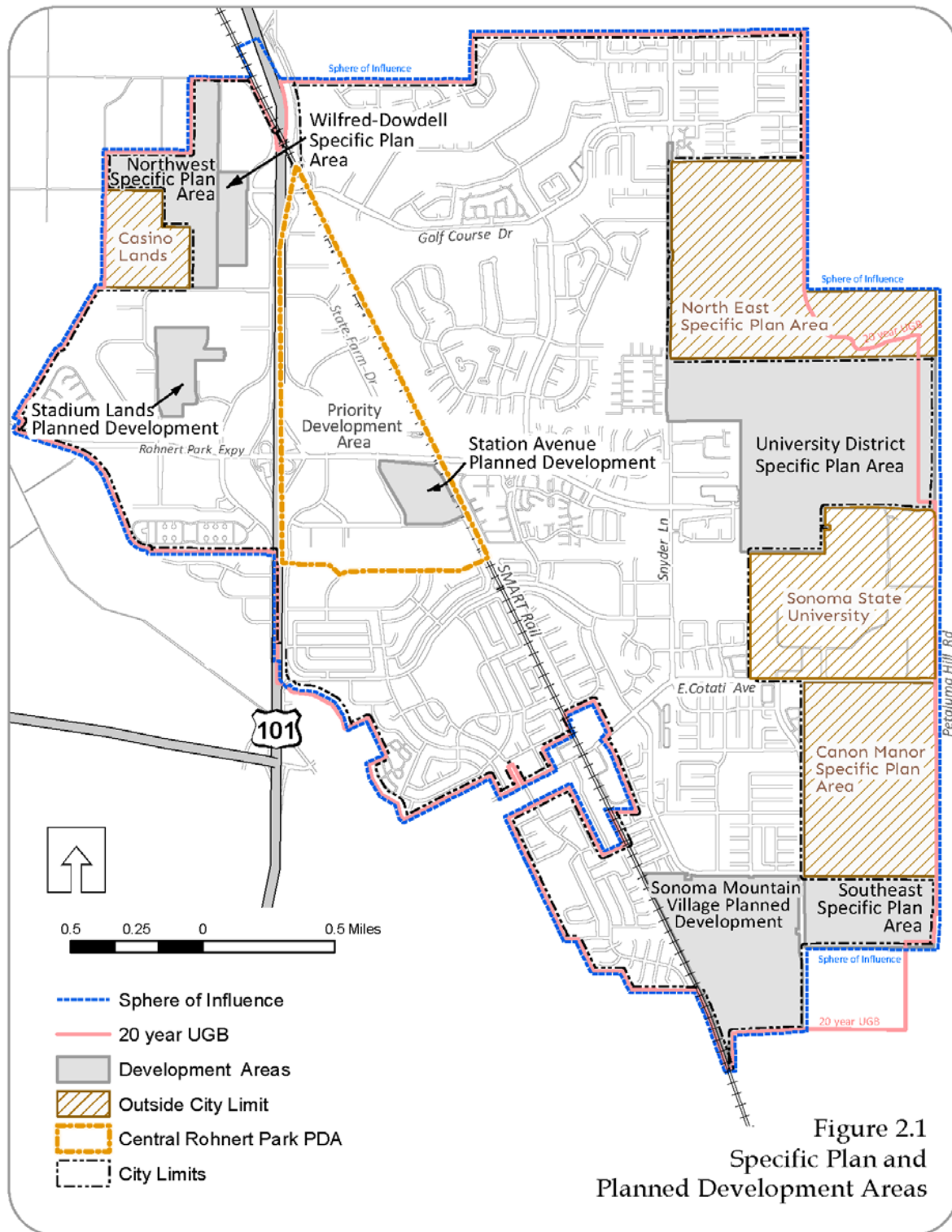

Table 2-1 Current and Planned Development*

Phase	Area	Parcels	Owner	% of Total
1	29.2 ac.	108**	Varied – under active development; includes developer Penn Grove Mtn LLC	37%
2	16.0 ac.	129	Penn Grove Mtn LLC	20%
3	14.3 ac.	106	Penn Grove Mtn LLC	18%
4	20.1 ac.	76	Penn Grove Mtn LLC	25%

*Includes 2 lots owned by Penn Grove Mtn LLC and changes to Phases 3 and 4 in 2019 Specific Plan amendment.

**Includes Mixed Use parcel for future apartments, townhomes and commercial.

D. Jurisdictions

The SESPA falls entirely within the city limits of the City of Rohnert Park. Other government agencies with jurisdiction in the plan area include:

- State of California Regional Water Quality Control Board, which reviews and regulates activities that affect water quality in California;
- State of California Department of Fish and Game, which reviews projects affecting fish and wildlife habitat; and
- Department of the Army - Corps of Engineers which regulates activities and development in the navigable waters of the United States
- U.S. Fish and Wildlife Service, which reviews and regulates activities that affect habitat of threatened and endangered species

3. LAND USE

A. Introduction

This section of the Specific Plan provides information and guidance on the range of land uses and the general levels of development to be accommodated within the SESPA. Also provided are development standards which provide more specific guidance on physical development parameters such as setbacks, building height, FAR's, and the like.

B. Land Use Policies

Information on the Land Use policies for the SESPA, which have been established in the General Plan, are provided in Attachment C: General Plan Analysis.

C. Land Use Designations

As shown in the City of Rohnert Park General Plan, the land uses intended for development within the SESPA include residential and mixed-use as well as a park.

Following guidance provided by the General Plan, the proposed development to be accommodated in the SESPA may be characterized as a residential community adjacent to the existing Canon Manor residential development and bounded to the east by Petaluma Hill Road, the south by Valley House Drive, and the west by Bodway Parkway. Within the residential community, as contemplated in the General Plan and shown in Figure 3-1: Conceptual Land Use Plan and illustrated in Figure 3-2: Conceptual Development Plan, different densities of housing will be accommodated. Adjacent to the residential development will be a mixed-used area. Incorporated within the fabric of the residential development will be a park to serve local residents. The Specific Plan has established 6 specific plan land use designations. Each specific plan land use designations is consistent with an existing general plan land use designation. Table 3-1: Permitted Uses identifies uses that are unconditionally permitted and those that require special permits or approvals. Those uses not specifically listed are not permitted unless determined by the City to be substantially similar to a listed use. A description of the specific plan land uses follows:

- The **Rural Estate Residential (RE)** land use is the lowest density land use, accommodating up to 2 single-family detached residential units per gross acre. This district is intended for very low-density residential development on large estate lots of typically 17,000 sq.ft. or larger in size. This district, located at the perimeter of the city, is intended to provide a transition from the more urban development to the open space/agricultural areas outside the city. This land use category is consistent with the "Rural Estate Residential" General Plan designation.
- The **Low Density Residential (LD)** land use designation is also intended for single-family detached residential units. The density for this land use designation is between 4.0 and 6.0 units per gross acre. This land use category is consistent with the "Low Density Residential" General Plan designation and can accommodate the following housing types:

- Conventional Lots: Units that take garage and front door access from the public street.
 - Executive Estate Lots.: Units that take garage and front door access from the public street. Executive Estates have larger, deeper lots and are able to accommodate a greater array of enhanced home options and backyard amenities, including accessory dwelling units..
 - Duets: Two attached units separated by a common lot line. Duets can be designed similar to conventional lots with garage access from the street or private drive/lane.
- The **Southeast Medium Density or SE Medium Density (SEMD)** classification envisions detached single-family housing and/or duets with an overall density ranges from 6.1 to 12.0 units per gross acre. This land use designation is consistent with the "Medium Density Residential" General Plan designation. The SE Medium Density Designation can accommodate a variety of lot types including:
 - Conventional Lots: Units that take garage and front door access from the public street.
 - Motorcourt Cluster: Units that take garage access from a private drive/lane and front door access from the public street and private drive/lane.
 - Duets: Two attached units separated by a common lot line. Duets can be designed similar to conventional lots with garage access from the street or private drive/lane.
 - The **Mixed-Use (MU)** land use classification envisions a development pattern that encompasses businesses, retail shops, institutions, service organizations and residences in a compatible, pedestrian environment. The appropriate residential component of this land use will be multifamily (apartments) and attached single-family units (townhomes). See Figure 3-3: Mixed Use Area. This land use allows for the development of integrated centers that combine a supportive mix of land uses, either within the same building or in clusters of buildings. This land use is consistent with the "Mixed Use" General Plan Designation.
 - The **Park (P)** land use classification accommodates neighborhood-scale park development to support the recreational needs of the adjacent residences. This land use designation is consistent with the "Parks/Recreation" General Plan designation.

In addition to the aforementioned land uses, Figure 3-1 designates 3 view corridor areas that have been sited to preserve and enhance views to the eastern ridgeline of the hills east of Petaluma Hill Road. Each corridor shall consist of a 50-foot wide area of land at the terminus of the street. No structures shall be permitted within these corridors, except for transparent (see-through) fences. No trees shall be planted within view corridors. Berms shall be permitted as necessary for sound attenuation.

A 50-foot buffer has also been designated along the length of Petaluma Hill Road to preserve the scenic qualities of this roadway. In no case shall trees or shrubs that exceed 25 feet in height upon maturity be planted within the buffer to preserve views.

Figure 3-1 Conceptual Land Use Plan

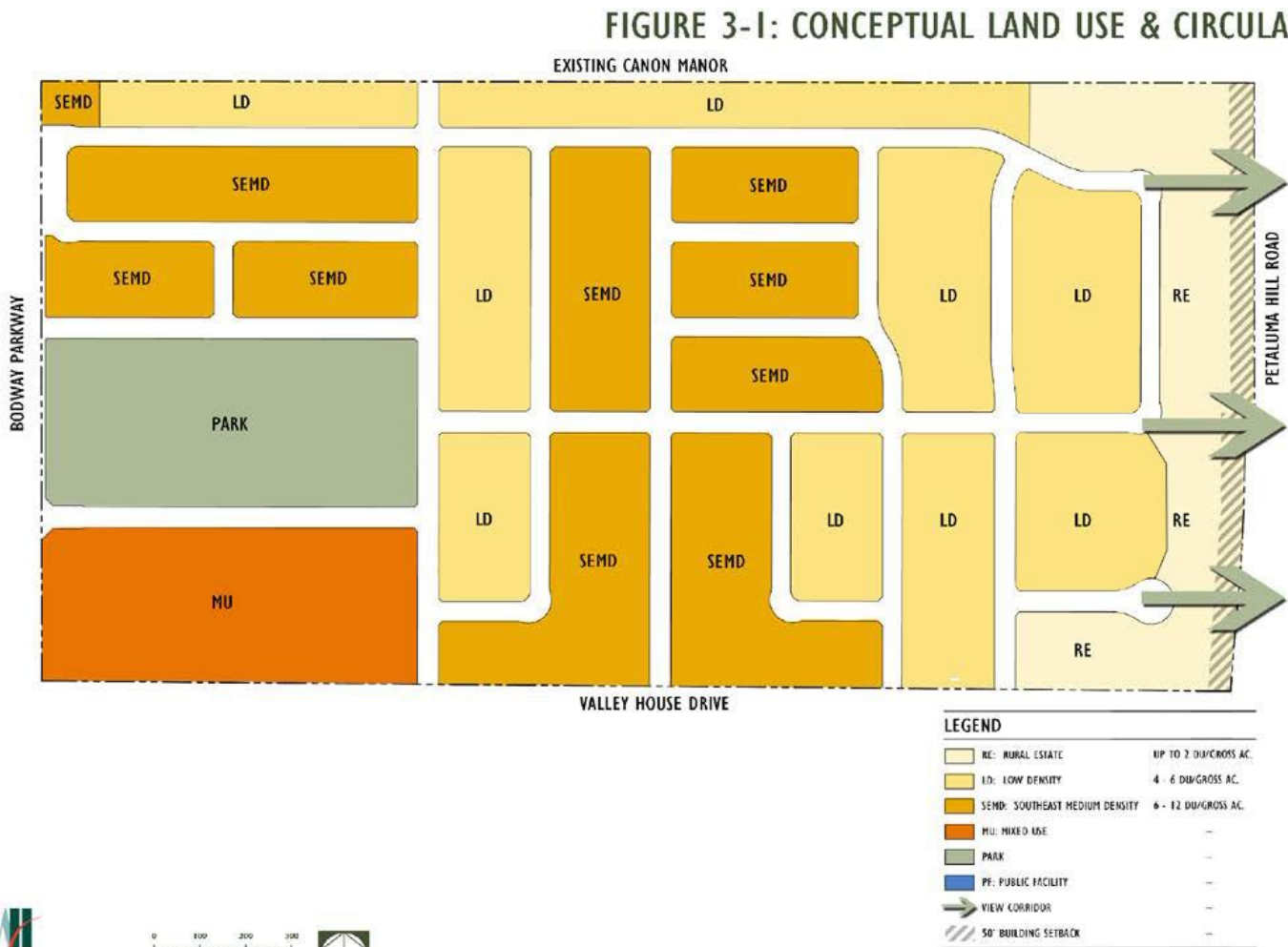

Figure 3-2 Conceptual Development Plan



Table 3-1: Permitted Uses

Land Use Category	RE	LD	MD	MU	P
Single Family Home	P	P	P		
Duets			P		
Townhouse				P	
Multi-Family Housing (Apartments)				P	
Secondary Unit	P				
Bed and Breakfast Inn				C	
Accessory Structure (non-habitable) – Shall be subject to RPMC Section 17.10.060	I	I	I		
Community Center				P	
Small Day Care Home (8 or fewer children)	P	P	P	P	
Large Day Care Home (9 or more children)	C	C	C	C	
Community Gardens	P				
Family Care Home/Residential Care Facility (6 or fewer people)	P	P	P	P	
Private School/Education	C	C	C	C	
Single Room Occupancy Boarding House	A	A	A		
Fraternity/Sorority	C	C	C		
Religious Assembly	C	C	C	C	
Antenna, Vertical/Satellite Dish, Communication Facility	C	C	C	C	
Home Occupation	P	P	P	P	
Amusement Center (video games, billiards, theatre or indoor amusement)				C	
Animal Hospital / Veterinary Clinic – small animals only, no outdoor facilities				C	
Bank/Savings & Loan/Credit Union				P	
Bar/Nightclub/Live Entertainment – subject to permitting requirements, refer to Land Use Footnote “r” Section 17.07				C	
Barber/Beauty Shop				P	
Health and Beauty Spa/Massage Therapy				C	
Clubs and Lodges/Public Assembly				C	
Dry Cleaning (only minor processing on-site)/Laundromat/Tailor				P	
Grocery/Food Market/Bakery				P	
Restaurant (café, microbrewery, sit-down or take-out)- refer to land use footnote R Section 17.07				P	
Retail Sales (Florist, Antiques, Interior Design, Hardware, clothing, etc.)				P	
Office (Professional/ Administrative/Medical/Dental)				P	
Laboratory (in conjunction with medical, dental or optical use)				P	
Professional Services (small scale postal, copy, printing)				P	
Medical Clinic				C	
Pharmacy (drive-through windows not permitted)				P	
Art Studios/Galleries (Photography, fine arts)				C	
Public Facility (Police, fire and other government uses)	C	C	C	C	
Studios (Dance, Martial Arts)				P	
Health Club				P	
Liquor Store (off-Sale) - subject to permitting requirements, refer to Land Use Footnote “r” Section 17.07				C	
Park, Playfield, playground, sport court					P
Detention Basin/Water Storage Facility					P

(P) Permitted (C) Conditionally permitted by Planning Commission (A) Administrative Permit (T) Temporary Conditional Permit (I) Uses Allowed as incidental to Primary Use

D. Land Use Designations Summary

Table 3-2: SESPA Land Use Program presents a comparison between the guidance provided in Table 2.4-3 Land Use Program: Southeast Specific Plan Area of the General Plan and the proposed Specific Plan.

Table 3-2: SESPA Land Use Program

Land Use	2000 General Plan (As Amended 2022)				Specific Plan			
	Gross Acres ¹	Density Range (Du/Ac)	Unit Range (Min. – Max)	Non-Residential Bldg Area (1,000 s.f.)	Approx. Gross Acres	Units	Density (Du/Ac)	Non-Residential Bldg Area (1,000 s.f.)
Rural Estate Residential	9.13	Up to 2.21	up to 20	n.a.	9.13	19 ²	2.1	n.a.
Low Density Residential	27.69	4-6	110-166	n.a.	27.69	160	5.8	n.a.
Medium Density Residential ³	27.77	6.1-12	169-333	n.a.	27.77	239	8.6	n.a.
Mixed Use Development	6.96	n.a.	81	10	6.96	81	n.a.	10
Parks	7.98	n.a.	n.a.	n.a.	7.98 ⁴	n.a.	n.a.	n.a.
Total	79.53	n.a.	360-600	10	79.53	499	n.a.	10

Notes:

1. Gross Acreage includes all rights-of-way located within the project boundary, measured to the center line of the street
2. Rural Estate residential unit count includes one existing unit.
3. In the Specific Plan, the SE Medium Density land use category is consistent with the Medium Density General Plan Land Use Designation.
4. Includes a 5.0 net acre park and a 2.1 net acre basin (7.1 net acres total)

As indicated in the table, the proposed specific plan land uses are generally consistent in terms of the General Plan’s vision for the Specific Plan area.

Figure 3-3 Mixed Use Area



E. Affordable Housing

The City of Rohnert Park's Affordable Housing Ordinance requires all new housing projects of five units or more to provide at least 15% of all units as affordable. This equates to 75 of the 499 total units within the SESPA. The ordinance provides a number of options to meet this requirement ranging from on-site construction, land donation to a non-profit developer, transfer of inclusionary unit credits and in-lieu fees for the construction of off-site affordable units. Additional affordable units may be provided in addition to the required inclusionary units.

The SESPA has been designed to allow for either on-site or off-site construction of affordable units. The Specific Plan's wide range of housing types including duets, apartments, townhomes, and small single-family homes, which provides numerous opportunities to provide on-site affordable housing consistent with the City's affordable requirements. The development agreement for the project includes the Affordable Housing Plan for the project.

4. DEVELOPMENT STANDARDS AND REGULATIONS

This Chapter describes standards for the development of each designation within the plan area. Table 4-1: Development Standards, sets forth the minimum requirements for lot area, coverage, floor area ratios, height, and setbacks, except as allowed through the City development and design review process, planned area process, or as otherwise indicated by the Specific Plan. The intention of these standards is to provide quantifiable guidance on the development desired in each of the land use categories.

For issues not specifically addressed by the development standards or the Specific Plan, the City of Rohnert Park Zoning Code shall apply and shall be based upon the most compatible zoning designation as determined by the planning director or his/her designee. Park development standards are intentionally excluded from Table 5-1: Development Standards. Park development standards shall be the same as those specified in the Parks (P-I) zoning district of the City of Rohnert Park Zoning Code.

Table 4-1: Development Standards

Development Requirement	Rural Estate	Low Density		Southeast Medium Density			Mixed-Use
		Conventional	Executive Estate	Conventional Lot	Motorcourt Cluster	Duets(1)	
Minimum Lot Area (SF)	17,000	5,000	6,000	3,000	3,000	1,800	n/a
Minimum Lot width (feet) (2)	90	50	50	35	50	30	n/a
Minimum Lot Depth (feet) (2)	100	90	120		55	60	n/a
Maximum Residential Density (du/acre)	2	6	6	12.0 (3)	12.0 (3)	12.0 (3)	24
Maximum Building Height (feet)							
Primary Building (4)	35	35	35	35	35	35	45
Accessory Structure (5)	12(6)	12	12	12	n/a	n/a	n/a
Minimum Front Setback (feet) (7)							
Porch	20	10	10	5 (8)	5 (8)	5 (8)	n/a
Primary Building	20	15	15	10	8	8	10
Garage (accessed from public street)	20	20	20	20	20	18	n/a
Garage (accessed from private aisle/lane)	n/a	n/a	n/a	18	18	18	n/a
Minimum Side Setback (feet) (7)							
Primary Building (interior lot line)	10	5	5	4	0/8 aggregate (10)	0/8 aggregate (10)	n/a
Primary Building (corner lot line)	20	10	10	10	7	10	10
Minimum Rear Setback (feet) (7)							
Primary Structure	25	15 (11)	20	10	10	5 (12)	10
Garage (detached)	5	5	5	5	n/a	n/a	n/a
Minimum Private Open Space Per Unit (SF)	n/a	750	1,500	400 (14)	350 (14)	250 (14)	50 (15)
Maximum Floor Area Ratio Factor (FAR)	Refer to City of Rohnert Park Zoning Code	Refer to City of Rohnert Park Zoning Code	Refer to City of Rohnert Park Zoning Code	Refer to City of Rohnert Park Zoning Code	Refer to City of Rohnert Park Zoning Code	Refer to City of Rohnert Park Zoning Code	2.0 commercial/ 1.15 Resid. (16)
Maximum Lot Coverage (%)	30%	50%	50%	50%	60%	70%	80%
Parking (17)	2 covered per unit (Plus 1 per secondary dwelling unit)	2 covered per unit (Plus 1 per secondary dwelling unit)	2 covered per unit (Plus 1 per secondary dwelling unit)	2 covered per unit (Plus 1 per secondary dwelling unit)	2 covered per unit (Plus 1 per secondary dwelling unit)	1 covered per unit (Plus 1 per secondary dwelling unit)	- Affordable Housing (2) - Refer to City of Rohnert Park Zoning Code
Fence/ Garden or Courtyard Wall Max Height (feet)							
Front Yards	4	4	4	4	4	4	4
Rear/ Side yards (18)	6	6	6	6	6	6	6
Secondary Dwelling Units (19)							
Max Height (feet)	28	n/a	n/a	n/a	n/a	n/a	n/a
Min Size (SF)	350	n/a	n/a	n/a	n/a	n/a	n/a
Max Size (SF)	700	n/a	n/a	n/a	n/a	n/a	n/a

Table 4-1: Development Standards Table 4-1 Notes:

1. Duets are two attached units located on two separate lots.
2. Dimensions are measured at the center of the lot. Flag lots are permitted.
3. Maximum Residential Density refers to the gross overall density for the overall specific plan land use district.
4. Towers, spires, cupolas, chimneys, elevator penthouse, water tanks, monuments, and similar structures and necessary mechanical appurtenances covering not more than twenty percent of the top floor roof area may exceed the maximum permitted height in the underlying zoning district by ten feet by conditional use permit.
5. Accessory structures are defined as detached structures such as sheds and small out structures not intended to serve as a living quarter. These are not permitted on duet lots, on mixed-use parcels, or within the 50-foot Petaluma Hill Road setback. All accessory structures shall meet the requirements of Rohnert Park Zoning Code section 17.10.060 as it pertains to accessory structures. For purposes of this specific plan, detached garages are not considered accessory structures.
6. All homes backing up to Petaluma Hill road shall be single story. No structures are permitted within the 50-foot setback, which is measured from existing right-of-way.
7. Minor projections such as bay windows, fireplaces, balconies, dormers and other minor architectural projections may encroach up to 2 feet into the front yard setback and up to 3 feet into side and rear yard setbacks. However, projections are allowed on one side yard only as one side must maintain at least 4' clear for full fire packs. Intrusions into setbacks shall not exceed more than 30% of the total length of one wall only. Full clearance on opposing side yard setback without overhangs is needed.
8. Front yard setback and Public Utility Easements may need to be expanded in specific locations to accommodate additional room for utility boxes, transformers, and other infrastructure pursuant to the requirements of the public utility company.
9. Duet garages may be accessed either directly from the street or private drive/lane
10. Minimum setback to property line may be 0' or 3' minimum; however, the aggregate distance between buildings shall be no less than 8 feet.
11. Dimension may be reduced to a minimum of 10 feet for up to 55% of the width of the building.
12. Due to the configuration of duet units, the rear setback is often synonymous with the side yard setback. Garages may be setback a minimum of 5 feet in either condition; however, living areas shall be setback a minimum of 10 feet when adjacent to another lot's private rear yard.
13. Garage access from a private drive / lane shall have a minimum driveway apron dimension of 5 feet or less or 18 feet or more to deter parked cars from blocking the drive aisle. This dimension shall be measured from the edge of the drive aisle/ lane to the face of garage door.
14. Private open space shall provide a minimum dimension of 10 feet in any one direction. Private open space may be provided in the front, rear or side yards as long as the area is defined by a fence or wall and may be split into two areas if necessary. Private open space areas may be split into two separate areas as long as the minimum dimension is met for all spaces and the cumulative area of all spaces meets the minimum area requirement.
15. This requirement applies to residential uses only and may be provided in the form of balconies, porches or decks. The minimum dimension shall be 6 feet.
16. FAR for commercial buildings shall not exceed 0.4. FAR for residential building shall not exceed 1.15 and shall have a minimum density of 12.2 du/ac. Mixed use buildings, if proposed, are permitted to increase the FAR in accordance with the General Plan.
17. Tandem spaces are permitted in order to meet the parking requirements.
18. Wall and fence heights may be increased to allow for sound attenuation per the recommendation of an acoustical study.
19. Secondary units are defined as either an attached or detached unit intended for use as a separate living unit but under the same ownership as the primary unit. Secondary units must include separate access, a bathroom, a kitchenette, and a separate parking space. This space may be provided as a tandem garage space or an uncovered space but must be located on the same lot as the unit. Secondary units shall be subject to the same minimum setbacks as the primary structure. Secondary units are only permitted on Rural Estate Lots.
20. Affordable housing projects parking ratio shall comply with California Government Code Section 65915-65918 Density Bonus Parking Requirement.

5. CIRCULATION ELEMENT

A traffic noise assessment was performed as part of the SESPA planning process to determine the extent to which traffic along the major thoroughfares adjacent to the area had the potential to generate noise levels in excess of established standards. The findings of this assessment are that noise generated by traffic along Petaluma Hill Road, Bodway Parkway, and Valley House Drive is anticipated to be such that mitigation measures such as sound walls, berm, setbacks, or any combination of these would be required. The precise design and configuration of these measures will be developed in collaboration with City representatives.

Circulation in the Southeast Area consists of a series of Arterials, Collector, and local roadways as illustrated in Figure 5-1: Circulation Plan. Existing roadways surrounding the site include Bodway Parkway, Valley House Drive, and Petaluma Hill Road. Bodway Parkway is an existing Major Collector. The project will improve Bodway Parkway within the existing right-of-way by adding an additional 6-foot sidewalk to the easterly side of the street, along the project's frontage. Valley House Drive and Petaluma Hill Road are both Minor Arterials. Improvements to Valley House Drive include a meandering 8-foot wide Class I bikeway/sidewalk. Petaluma Hill Road improvements include widening the existing roadway by 20 feet to accommodate left and right turn lanes at the signalized intersection at Valley House Drive, a 7-foot sidewalk with curb and gutter, and an 8-foot multi-use path with curb and gutter, and a 6-foot on-street bike lane. All new roadways interior to the project area consist of Minor Streets, 42-foot wide Neighborhood Streets, and 24 feet wide private drives and 20-foot wide private drives at motorcourts. All streets, except for private drives and motorcourts, are public.

The Design Guidelines presented in Chapter 6 of this document provide additional guidance and direction in planning for new development.

A. Existing Circulation

Existing circulation in the vicinity of the SESPA is provided via three principal roadways including Petaluma Hill Road, located on the eastern boundary of the site which is the principal north/south regional roadway, Valley House Drive to the south serving east-west traffic, and Bodway Parkway to the west, also serving north/south movements. The ~~Phase 4~~ interior circulation system for Phases 1-2 is complete and the Phase 3 interior circulation system is under construction.

B. Roadway Classifications and Standards

The General Plan provides guidance on the sizing and physical and functional characteristics of roadways within the City of Rohnert Park. For the SESPA, the General Plan's Master Street Plan (Figure 4.1-1 in the General Plan) indicates the following classifications for roadways shown on the Plan:

- Bodway Parkway: Minor Collector (2 lanes) [Per Resolution N. 2021-097]
- Valley House Drive: Minor Arterial (4 lanes) [Proposed]

- Petaluma Hill Road: Minor Arterial (2 lanes) [Existing]

The street sections which correspond to these classifications are shown in Attachment A: the Public Services Plan.

C. Transit Service

Transit services in the vicinity of the SESPA are provided by Sonoma County Routes 44, 46 and 52 that operate on Petaluma Hill Road and Camino Colegio. The project, when implemented, will add incrementally to the demand for transit services that can be met by the transit provider.

D. Pedestrian and Bicycle Circulation

Pedestrian and bicycle circulation within the SESPA will be facilitated by a network of sidewalks and bicycle lanes which will be developed along with the roadway system. This system is demonstrated in Figure 5-1: Circulation Plan. The local street system has been designed as a grid network of streets with sidewalks, short blocks, and multiple intersections to maximize connectivity and allow pedestrians to maneuver easily throughout the SESPA. A direct east-west connection has been provided in the form of a through street that extends from the park/mixed use area and the Rural Estate neighborhood. This connection along with one through north-south connection has been designated as a "Major Pedestrian Corridor". Major Pedestrian Corridors are intended to provide direct connections through the site for pedestrians traveling along these sidewalks. Neck-downs or bulb-outs shall be provided at key intersections to promote safer pedestrian street crossings.

In addition to improved connectivity within the site, an 8-foot multi-use trail along Valley House Drive and a 6-foot sidewalk along Bodway Parkway provide both bicyclists and pedestrians with easy access to adjacent neighborhoods. The multi-use trail will be grade-separate from the street, providing a safer environment for trail-users. Both the Valley House and Bodway pedestrian corridors are also considered Major Pedestrian corridors and should be carefully designed to minimize driveway accesses and vehicular interruptions. This may be achieved through the use of motor court homes or by siding homes onto these roadways.

The Valley House Drive and Bodway Parkway pedestrian corridors have also been designed to promote connectivity with existing and planned adjacent neighborhoods by providing direct connection to existing sidewalks and providing enhanced pedestrian crossings to future development planned just west of the SESPA. Figure 5-1 demonstrates the conceptual location for these crossings. Crossing enhancements may include features such as bulb-outs, enhanced paving materials, lighted crosswalks or other design features that alert vehicles of a pedestrian presence and encourage drivers to slow down. The final designs of these intersections are subject to future review and approval by the City of Rohnert Park.

E. Private Drive / Lane

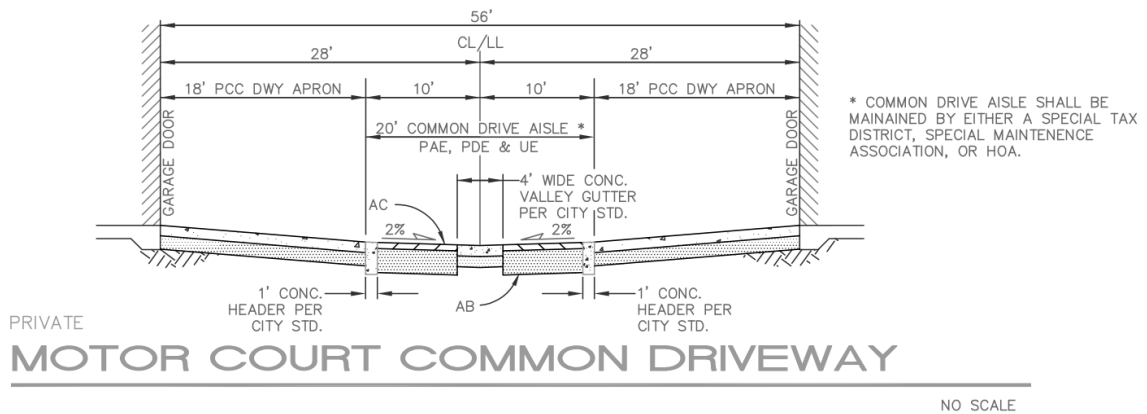

1. Dead end lanes are allowed if lane length does not exceed 150'.
2. Maximum 6 residential units.
3. No parking shall be allowed.
4. Lanes shall connect to streets that provide minimum 20' clear width.
5. Access shall be through a Standard 250 A, C, or D curb cut unless otherwise approved by the City Engineer.
6. Lighting shall meet the City's minor street requirements for uniformity ratio and minimum maintained foot candle specifications. All streetlights shall be LED.
7. Signs will be posted with "No Parking Fire Lane"

F. Projected Traffic Volumes

In order to assess the potential demands for transportation services in the SESPA and given the possibility of different types of commercial development within the mixed-use area, two alternative scenarios were used. One examined the development of the 20,000 s.f. of space for a small retail center while the other analyzed the requirements for office development. Under the first scenario, the retail center, an average of about 5,000 daily vehicle trips would be generated while under the second scenario, the office development, the trips would be somewhat lower. Refer to the Southeast Specific Plan Traffic Impact Study, which is on file with the City of Rohnert Park Planning Division (File numbers 2003-031, -054 and -005).

G. Emergency Vehicle Access

Access for emergency vehicles, including police and fire, will be provided via the network of streets that will be developed as part of the project.

H. Phasing

As shown in Figure 5-2, Conceptual Phasing Plan, the project will be developed in several phases according to market demands. At each stage of development, roads will be constructed to provide access to the new residences while ensuring a logical roadway pattern is available for utility services, fire access, and life safety equipment as needed and appropriate. The first three phases are under active development at this time.

Figure 5-1: Circulation Plan



Figure 5-2: Conceptual Phasing Diagram

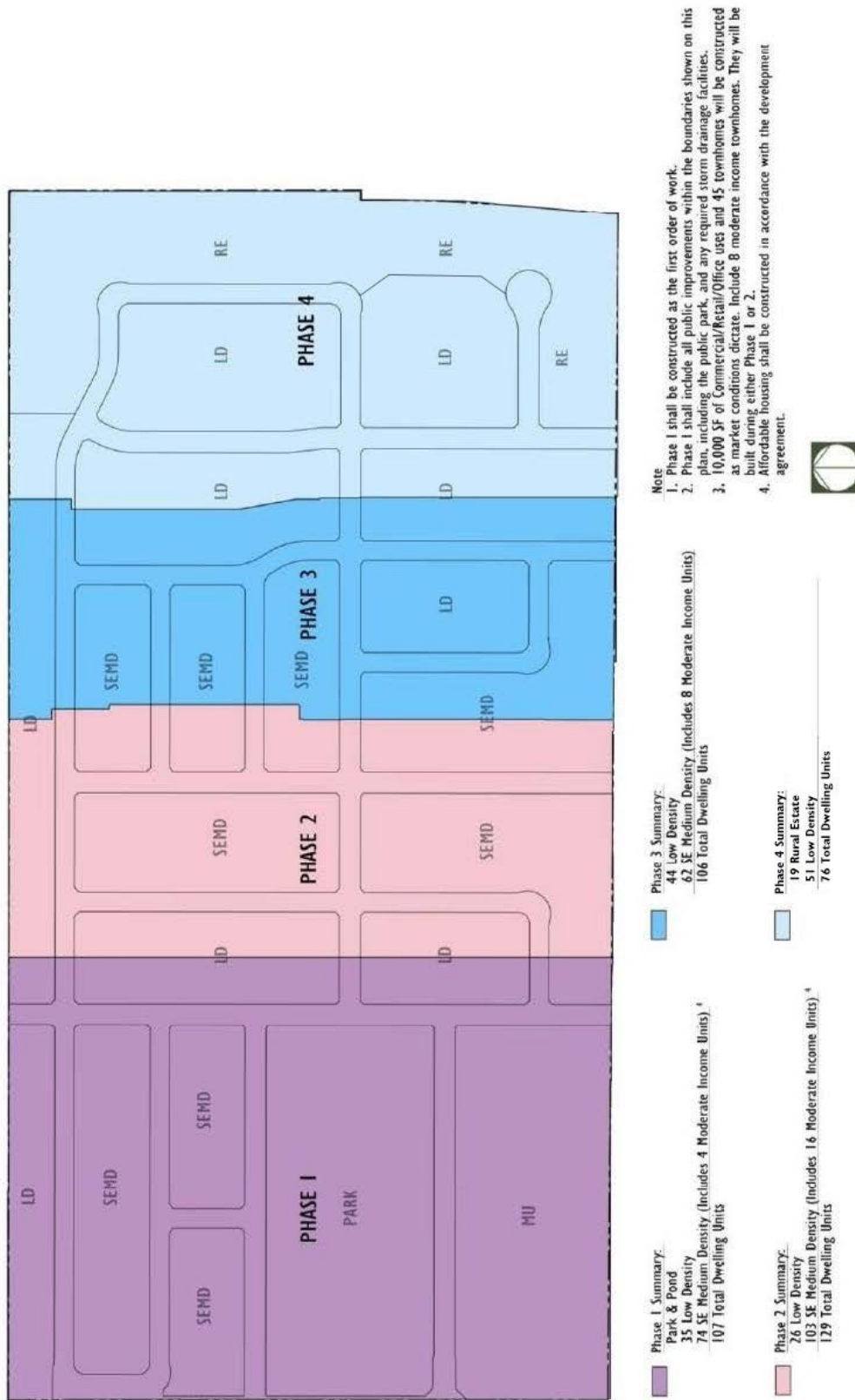

6. PUBLIC SERVICES ELEMENT

A. Introduction

In support of the residential, mixed-use and park development within the SESPA, public services will be required. These services include access and circulation, water service, sanitary sewer service, and storm drainage management. The Public Services Plan, provided as Attachment A, describes the delivery approach concepts for each of these systems. Following are brief summaries of the planned improvements for each service.

B. Access and Circulation

The existing roadways which provide primary access to the SESPA, i.e. Petaluma Hill Road, Valley House Drive, and Bodway Parkway, will require different levels of improvement in order to accommodate the future transportation demands generated by the new development. In the case of Petaluma Hill Road, which is a fully improved county highway, the project will include the installation of additional pavement to allow for the installation of an 8-foot bike lane constructed according to County Standards along the project's frontage. A traffic signal at the Petaluma Hill Road/Valley House Drive intersection already exists as well as a new left and right turn lanes at the traffic signal. South of Valley House Drive, additional pavement will also be added to accommodate longer deceleration lanes. Bodway Parkway will be upgraded from its existing situation (which includes two traffic lanes, a median and a bikeway/sidewalk on the western side of the roadway) to include a new 6-foot sidewalk on the east side of the parkway along the frontage of the SESPA. Finally, with the elimination of the property on the south side of Valley House Drive from the Urban Growth Boundary, the existing improvements to Valley House Drive are adequate to serve the proposed traffic flow. Improvements to both Bodway and Valley House are not included in the Public Facilities Financing Plan.

Streets and sidewalks required for internal circulation within the SESPA will be developed in accordance with the City of Rohnert Park Manual of Standards, Details and Specifications (most current edition).

C. Water Service

As part of the Specific Plan process the Rohnert Park Final Water Supply Assessment, (Winzler and Kelly, January 2005) was prepared to determine the availability of water needed to serve the project area. The Specific Plan also considers water conservation and a water conservation plan was prepared. Both the water assessment and the water conservation plan are on file with the City of Rohnert Park Development Services Department (File numbers 2003-031 and -054). Consistent with the objective of water conservation, low flow devices will be installed within the new homes and drought tolerant landscaping materials will be utilized. The developers of the SESPA will continue to work with the City of Rohnert Park to construct appropriate water saving and water generating projects, consistent with state law.

New development within the SESPA will pay the City's most current water capacity charge. This charge funds upgrades to the City's water system to serve new development. The project will need to construct or fund the construction of a 12" water main extension from the City's water tank on Camino Colegio to the project.

D. Sanitary Sewer Service

The owners of the SESPA property have entered into an agreement with the County of Sonoma and the developers of the Sonoma Mountain Village to provide a collector sewer system for Canon Manor, the Southeast Specific Plan, and the lands formerly owned by Agilent Technologies. This system consists of a gravity main from the intersection of Bodway Parkway and Camino Colegio, a sewerage lift station, and a force main to an adequately sized trunk line sewer provided by the Public Facilities Financing Plan. These facilities are complete.

E. Storm Drain System

Runoff and storm water, which requires management within the SESPA, will be collected and conveyed through a series of interconnected drop inlets, catch basins, manholes, and pipes. Rain gardens will be used in large residential lots and in the commercial and multifamily areas. Additional filtering or low impact design elements will be included in the design to meet SUSUMP requirements; storm water quality enhancement or cleaning for the 2-year storm event.

Except for the commercial and multifamily sections, all the storm water will tie into a storm water detention facility located adjacent to the park at the project's western boundary. The total area of the detention basin is about 1.8 acres. The storm water detention facility or detention basin will attenuate the increase in runoff created by the development of the property to be at the same present rate. This will result in no net increase in peak runoff in the 100-year storm event. In addition to attenuating the peak runoff, the detention facility will also provide a means of infiltration for ground water recharge and an improvement in water quality by settling of sediment. After release through the detention basin outlet structures, the runoff will drain into two existing systems located in Bodway Parkway and converge just to the west of the intersection of Bodway Parkway and Valley House Drive.

The point of reference within the watershed that is used to compare pre and post project flows is located on the Sonoma Mountain Village site. An existing storm drain in the Sonoma Mountain Village site currently conveys water from Bodway Parkway and the SESPA. This storm drain system will continue to serve the SESPA after development. This will be possible since the SESPA will have no net increase in peak flows up to the 100 year storm.

The upstream collection facilities will be funded by the developers of the SESPA. A Preliminary Stormwater Mitigation Plan has also been prepared as part of the Specific

Plan process and can be found on file at the City of Rohnert Park Planning Divisions (File numbers 2003-031 and -054).

F. Parks and Recreation

A new community park is proposed within the SESPA as shown in Figure 10: Master Park Plan. This Public Services Plan proposes a 5 ± net acre park and, rectangular in nature, adjacent to Bodway Parkway. The park's proposed east-west orientation allows it to be integrated into the SESPA's proposed pedestrian promenade and view corridor.

G. Schools

The project proponents have contacted the Cotati-Rohnert Park Unified School District to determine services available to the Southeast Area. A school district representative indicated that currently the Southeast Rohnert Park Specific Plan area would be served by the following schools:

Elementary School:	Monte Vista
Middle School:	Lawrence E. Jones Middle School
High School:	Rancho Cotate & Technology High

H. Police and Fire

The City of Rohnert Park Department of Public Safety will provide police and fire services to this area. The Department of Public Safety provides police, fire and other related services with cross-trained personnel under a single administrative umbrella. SESPA can currently be served by the City's Fire Station in M section. The City's Public Facilities Financing Plan includes funding of a new fire station in the southwest portion of the City to serve planned growth.

I. Finances

Major off-site infrastructure is paid for by the City's Public Facilities Financing Plan and the Water Capacity Charge programs. The SESPA development will pay into these fees.

Ongoing maintenance for service for the SESPA project will funded by special tax assessments collected through a Community Facilities District (CFD). The services funded by the special taxes include provision of public safety services that are in addition to those services provided before the formation of the Community Facilities District; the maintenance, rehabilitation and reconstruction of publically owned pavement; the maintenance, rehabilitation and reconstruction of publically owned landscapes, parks,

playgrounds, signage, curbs, gutters, sidewalks, decorative walls and street lighting; and the permitting, operation, maintenance, monitoring, rehabilitation and reconstruction of publicly owned drainage and storm water treatment systems within the District. This also includes all the appurtenances and work (such as engineering, planning, designing, construction and coordination) to provide and maintain the services.

The special tax rate for the CFD is established annually. The calculations to establish the tax rate are informed by the provisions of the Development Agreement between the developer and the City.

7. DESIGN GUIDELINES

The Design Guidelines are presented as Attachment B to this document.

8. IMPLEMENTATION ELEMENT

A. Development Review and Approval

The Southeast Specific Plan was approved by the City Council in 2010 and annexation of the site to the City was completed in 2011. Both actions were subject to preparation of an Environmental Impact Report (EIR) to evaluate the environmental effects of these actions. The City Council certified the EIR in taking action on the project. In 2014, minor amendments to the Specific Plan and Development Area Plan were approved to eliminate alley-loaded single family lots and incorporate motorcourt homes.

Final maps for Phases 1 and 2 have been approved and construction of homes within those phases is underway. The neighborhood park on the western side of the project is nearing completion. Current amendments to project plans are proposed to reflect a better understanding of development patterns.

B. Financing

The developers of the SESPA will fund the installation of public facilities and services in the SESPA and will also contribute through the City of Rohnert Park Public Facilities Financing Plan and agreements with the County of Sonoma for the funding of off-site services. These fees also include school mitigation fees, park fees, sewer and water connection fees, storm drain fees, engineering plan check fees, grading plan and permit fees, building plan and permit fees, housing in-lieu fees, traffic signal fees, and area-wide impact fees.

The maintenance of open spaces, landscape medians and other similar features will be financed through the established Community Services District.

C. Amendments to the Specific Plan

Amendments to this Specific Plan shall be made in accordance with applicable sections of the Rohnert Park Municipal Code, Chapter 17.06, Article VIII, Section 17.06

List of Attachments:

Attachment A: Public Services Plan, Civil Design Consultants, Inc. October 27, 2010

Attachment B: City of Rohnert Park Southeast Specific Plan Design Guidelines, prepared by William Hezmalhalch Architects, Inc. May 2006

Attachment C: General Plan Analysis

List of Related Technical Studies (on File at the City of Rohnert Park Planning Division File no. 2003-031, -054, and -005)

- City of Rohnert Park Southeast Specific Plan Preliminary Application, presented by Redwood Equities, LLC, February 2002
- Final Report – Southeast Specific Plan Market Analysis, Economic & Planning Systems, Inc. February 2002.
- Final Report – Southeast Specific Plan Market Analysis, Economic and Planning Systems, February 2002; a revision to this report was prepared in 2006.
- Updated Geotechnical Engineering Investigation – Proposed Residential Development 7279 Petaluma Hill Road, Rohnert Park, California, Southeast Specific Plan, Michelucci & Associates, Inc. December 2002.
- Results of 2001 Survey for Special-Status Plant Species, Southeast Specific Plan Area, Rohnert Park, California; Laurence P. Stromberg, Ph.D., Wetlands Consultant; May 2001.
- Jurisdictional Delineation – Redwood Equities, LLC Property, Gibson & Skordal, LLC, Wetlands Consultants, June 2002
- Letter: from Calvin C. Fong, Chief, Regulatory Branch, Department of the Army, San Francisco District, Corps of Engineers, to Tom Skordal.
- A Cultural Resources Evaluation of the Southeast Specific Plan Area, in Rohnert Park, Sonoma County, California, submitted by Archaeological Resource Service, January 2002.
- Southeast Specific Plan Traffic Impact Study for the City of Rohnert Park, Whitlock & Weinberger Transportation, Inc. January 2003.
- Addendum to SESPA Traffic Impact Study, Whitlock & Weinberger Transportation, March 6, 2003.
- Environmental Site Assessment, Phase 1 Investigation, Harris & Lee, Environmental Sciences, March 2001.
- Traffic Noise Assessment, Illingworth & Rodkin, Inc. April 6, 2003.
- Public Facilities Financing Plan, Harris and Associates, May 25, 2004
- Public Services Plan, Civil Design Consultants, Inc. 2003.
- Rohnert Park Final Water Supply Assessment, Winzler and Kelly, January 2005
- Water Conservation Plan for Southeast Specific Plan, John Olaf Nelson Water Resources Management, May 2008
- Preliminary Stormwater Mitigation Plan, Civil Design Consultants, Inc., 2008 Preliminary Stormwater Mitigation Plan